

PEAVEY[®]
ARCHITECTURAL ACOUSTICS[®]

LX™ 25

Unidirectional Lavalier Microphone

SPECIFICATIONS

SPECIFICATIONS:

Element Type:

Electret Condenser

Polar Pattern:

Unidirectional (Supercardioid)

Front-To-Rear Rejection:

Over 20 dB at nulls (typical)

Impedance:

Low (approximately 500 Ohms, balanced)

Frequency Response:

50 to 15,000 Hz

Sensitivity:

Output Power Level:
-53 dB (0 dB = 1 mW/Pascal)

Open Circuit Voltage:
-70 (0 dB = 1 Volt/dyne/cm²)

Maximum SPL:

124 dB at 1 kHz

S/N Ratio:

Better than 60 dB (re 1 Pascal)

Connector (Output):

3 pin XLR type

Switch:

Rocker on-off (Battery only)

Power Requirements:

Internal battery, 1.5V, Size AA or,
Phantom 7-52V

Battery Life:

Greater than 1000 hrs. continuous
(Alkaline types)

Finish:

Microphone and power module: Low
gloss black

Phasing:

Positive (inward) pressure on diaphragm
produces positive voltage at pin #2

Cable (Microphone):

4.1' (1.1m) long, 0.1" (2.6mm) diameter
Switchcraft® TA3F at Power Module end

Dimensions:

Microphone: See Figure 2
Power Module: See Figure 2

Weight:

Microphone: 5 oz. (14 gm) (without cord)
Power Module: 4.3 oz. (122 gm) (with
battery)

Furnished Accessories:

Clothing clip, battery, foam windscreen
and sturdy carrying case

FEATURES:

- Unidirectional polar response to minimize feedback and pickup of ambient noise

- Compact, unobtrusive design
- Well-balanced frequency response for natural reproduction of the off-axis voice projection, and of many acoustic musical instruments
- Battery and/or phantom powering. Phantom overrides battery, and battery automatically takes over if phantom power is interrupted
- On-off switch for muting - switches battery only
- Compact, rugged power module houses battery, switch, electronics and microphone connectors
- Microphone may be unplugged at power module for convenience in storage, interchange of microphones, and for ease in dressing performers
- Foam windscreen supplied for outdoor use

DESCRIPTION

The LX™ 25 is a compact lavalier microphone system featuring unidirectional performance, and designed for high voice quality and application versatility.

The well-balanced response and very effective unidirectional properties also make the LX 25 well-suited for the pickup of many acoustic musical instruments such as guitars, violins, saxes and more.

The LX 25 can dramatically reduce feedback potential in such public address applications as churches, auditoriums and lecture rooms.

The LX power module provides for simple battery replacement, and may be plugged directly into chassis receptacles for convenience in channel checks or for use as a body-worn talk-back microphone.

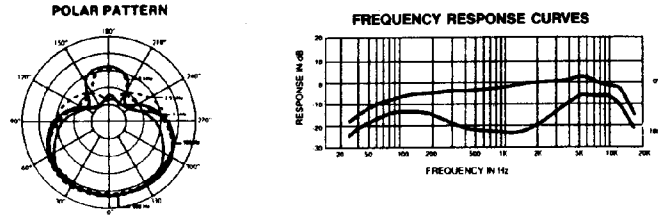

Figure 1

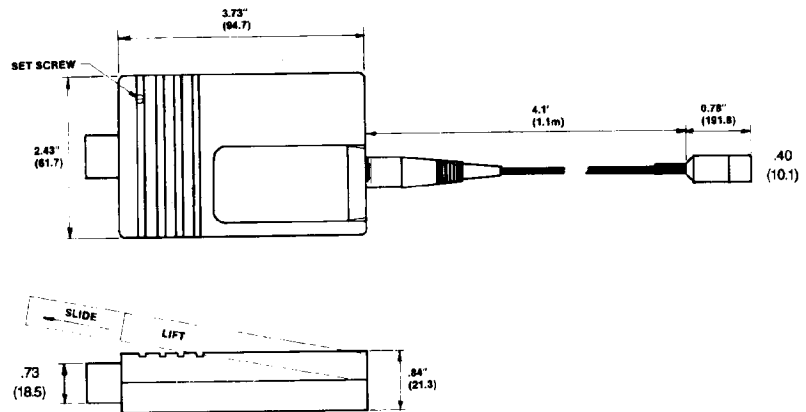

Figure 2

BATTERY INSTALLATION AND REPLACEMENT

To install or replace battery, remove single screw in case side near output connector.

Gently lift case side to clear output connector and slide from under retaining clip above name plate. Remove case side and insert AA battery into battery compartment, observing polarity (+ and -) markings.

Slide nameplate end of case side under retaining spring. Pressing down on output connector end, slide forward until the case side locks around the connector, and replace screw.

ONE YEAR LIMITED WARRANTY--

Note: For details, refer to the warranty statement. Copies of this statement may be obtained by contacting Peavey Electronics Corporation, P.O. Box 2898, Meridian, Mississippi 39302-2898.

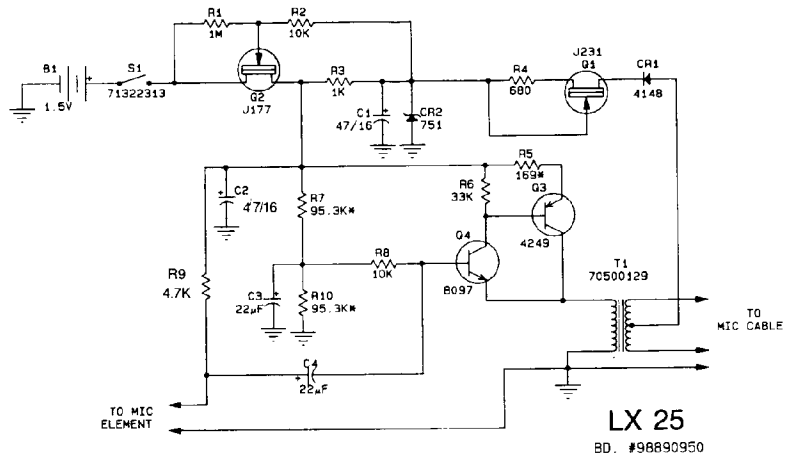

NOTES:
 ALL RESISTORS 1/4W UNLESS NOTED
 ALL RESISTORS IN OHMS UNLESS NOTED
 ALL CAPACITORS IN MFD UNLESS NOTED
 ALL DIODES 1N4148 UNLESS NOTED
 LAST REFERENCE DESIGNATOR USED:
 R10 CR4 C4 S1 T1 B1
 * DENOTES 1% TOLERANCE

LX 25
 BD. #98890950

Figure 3



Features and specifications subject to change without notice.

A Division of Peavey Electronics Corporation

711 A Street, P. O. Box 2898, Meridian, MS 39302-2898 / (601) 483-5376 / Telex: 504115 / Fax: (601) 484-4278